



iPower Collaboration System Tips and Troubleshooting

Copyright © 2002: Polycom, Inc.

Polycom, Inc., 4750 Willow Road, Pleasanton, CA 94588

www.polycom.com

Polycom, the Polycom logo, and Vortex are registered trademarks of Polycom, Inc. Global Management System, IDEC, ImageShare, iPower, LAMB, Look-At-Me-Button, PathNavigator, PowerCam, PowerMic, and WebOffice are trademarks of Polycom, Inc.

Bose is a registered trademark of Bose Corporation.

Intel is a registered trademark of Intel Corporation.

Microsoft, NetMeeting, PowerPoint, Windows, and Windows NT are registered trademarks of Microsoft Corporation.

HP is a registered trademark of Hewlett-Packard Company.

Netscape is a registered trademark of Netscape Communications Corporation.

All other product and company names are the trademarks or registered trademarks of their respective owners.

The information contained in this document is subject to change without notice. Polycom assumes no responsibility for technical or editorial errors or omissions that may appear in this document or for the use of this material. Nor does Polycom make any commitment to update the information contained in this document. This document contains proprietary information which is protected by copyright. All rights reserved. No part of this document may be photocopied or reproduced in any form without the prior written consent of Polycom, Inc.

Edition: 3725-50171-001/A

Do you have any suggestions or comments on the documentation for this product? If so, please send them by email to iDesign@polycom.com .

Contents

About This Guide

Chapter 1 - Presenting the Polycom iPower Systems

About the iPower Systems	1
Standard Hardware Components	3
Computer Box	3
iPower 9000 System.....	3
iPower 600 System.....	3
iPower 900 System.....	4
Main Camera	4
iPower 9000 System.....	4
iPower 600 System.....	5
iPower 900 System.....	5
Remote Control Devices	5
iPower 9000 System.....	5
iPower 600 and iPower 900 Systems	6
PowerMic.....	7
ImageShare or ImageShare II.....	7
iPower 9000 and iPower 600 Systems	7
iPower 900 System.....	7
Optional Hardware Components.....	8
Display	8
Cart	9
Additional Cameras	9
VCR.....	10
Other Optional Hardware Components	10
Standard Software Applications.....	11
Optional Software Applications	12

Chapter 2 - AdminTools Roadmap

Customizing the System	14
Setting Up System Security	14
Configuring Network Use.....	15
Configuring Audio	15
Configuring Video.....	16
Configuring Streaming	16
Setting Up Directories	16
Allowing Data Sharing	17
Maintaining the System	17
Using Remote Management Tools	17
Configuring Multipoint Conferencing	18

Chapter 3 - Tips for Tasks You Do Rarely

Setting Up the Log On Process	19
Choosing Logon Options	19
Setting Up User Accounts for Standard Windows Logon	20
Setting Up Additional Software	20
Remote Management Software	20
WebRemote	20
SNMP Management.....	22
Global Management System.....	22
Document Servers	24
PathNavigator Conference-on-Demand	25
WebOffice.....	26
Restoring the System.....	28
Getting Ready to Reinstall	28
Reinstalling the iPower System.....	28
iPower 9000 and iPower 900 Systems	29
iPower 600 System	29

Chapter 4 - Tips for Tasks You Do Regularly

Adding Applications.....	32
Monitoring System Statistics	32
Viewing Detailed System Statistics	32
Viewing the Configuration Summary.....	34
Viewing Statistics for the Current Call	35
Accessing and Viewing Logs	36
Setting Up Virus Protection	37
Conserving Disk Space	37

Chapter 5 - Tips for Helping Users

Making Sure Users Have the Information They Need	39
Sending the “Quick Tips Sheet” to Users	39
Customizing the “Getting Started Guide”	40
Displaying Room Information on the iPower System Home Page.....	40
Making Sure Users Know How to Contact the System Administrator.....	41
Finding Information in the Documentation	42

Chapter 6 - Troubleshooting Tips

Solving Installation Problems	46
Solving Startup Problems.....	46
Solving General System Problems	47
Solving Network Problems	49
Solving Video Problems	55
Solving Audio Problems.....	59
Solving ImageShare and ImageShare II Problems	61

Appendix A - System Default Settings

About This Guide

This guide is for system administrators who need to configure, maintain, and troubleshoot the Polycom® iPower™ 9000, iPower 600, and iPower 900 systems.

Complete information about the iPower systems is available through the online help. For installation information, refer to the hardcopy installation documentation. Users can also refer to the documentation available on the *iPower Documentation Library* CD. Both the installation documentation and the CD are shipped with each iPower system. (For titles and descriptions of all the iPower documentation, see Chapter 5, “Tips for Helping Users.”)

For support or service, please contact your Polycom service provider or call Polycom Technical Support. You can find phone numbers for Technical Support in your area, as well as the latest product information, at the Polycom web site, www.polycom.com.

1

Presenting the Polycom iPower Systems

This chapter provides an overview of the three Polycom iPower systems. It includes these topics:

- ❑ About the iPower Systems — Describes each iPower system.
- ❑ Standard Hardware Components — Describes the hardware components that come standard with each system, such as the computer box, cameras, and remote control devices.
- ❑ Optional Hardware Components — Describes the hardware components that you can purchase separately, such as displays, carts, and additional cameras.
- ❑ Standard Software Applications — Describes the software applications that come standard with each system, such as the Collaboration application, AdminTools, and Hardware Diagnostics.
- ❑ Optional Software Applications — Describes the software applications that you can purchase separately, such as the Polycom Document Server, Polycom PathNavigator™ Conference-on-Demand, the Polycom Global Management System™, and WebOffice™.

About the iPower Systems

The Polycom iPower systems are state-of-the-art visual collaboration tools. Each allows users to exchange ideas and share documents with people anywhere in the world, as if they were all in the same room.

Three versions of the iPower system are available: the iPower 9000, the iPower 600, and the iPower 900.

- ❑ The iPower 9000, like all iPower systems, provides quality audio and video, as well as easy-to-use data sharing capabilities. You can install the iPower 9000 system in a 19-inch (48.26 cm) equipment rack, on top of a desk or credenza, or in a cart.

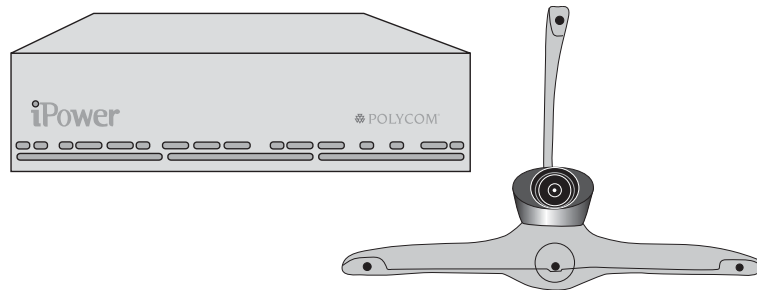

- ❑ The iPower 600 system comes in a unique package. You can install it as an all-in-one appliance, so that it conveniently fits on top of a traditional monitor. Or, you can split it into two components: the Camera and Microphone module, which you can easily mount on a flat-panel display or wall, and the compact computer unit.

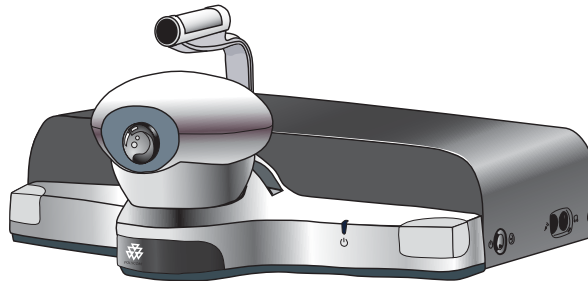

- ❑ The iPower 900 system, like the iPower 9000 and iPower 600, utilizes a conventional PC platform, enabling you to use it for more than just video calls. For example, you can use it for collaborating on documents, surfing the web, sending email, accessing corporate databases, and more.

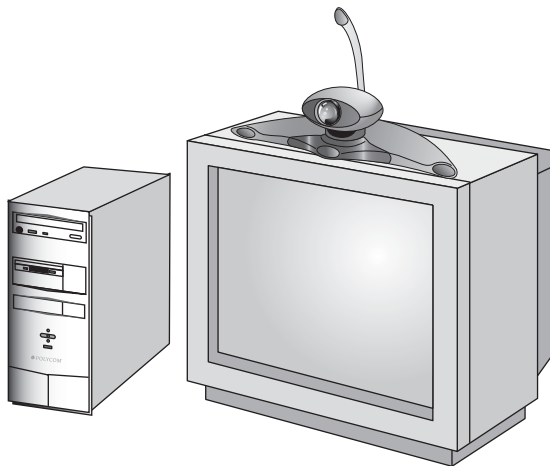

Standard Hardware Components

The following hardware components come standard with each iPower system:

- Computer box
- Main camera
- Remote control devices
- ImageShare™ or ImageShare II

Computer Box

iPower 9000 System

The computer box contains the system software, internal hardware, and power supply.

To locate the power button on the iPower 9000 computer box, flip down the front cover. The CD-ROM drive is also located at the front, whereas the connection panel is located at the rear.

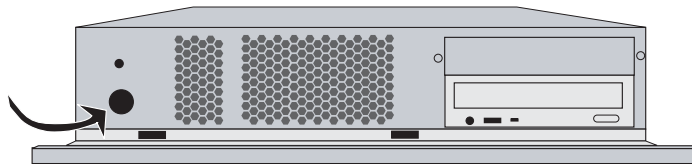

iPower 600 System

The computer box is known as the *computer unit* for the iPower 600 system.

The power button on the iPower 600 is located on the side of the computer unit. The connection panel is at the rear.

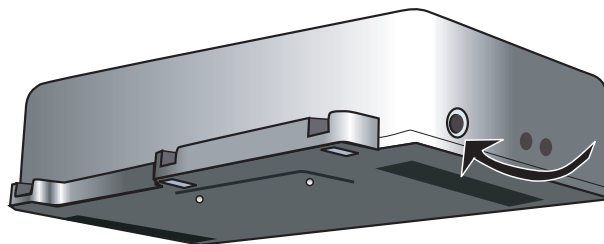

iPower 900 System

The power button, as well as the CD-ROM drive and diskette drive, on the iPower 900 are at the front of the computer box. The connection panel is located at the rear.

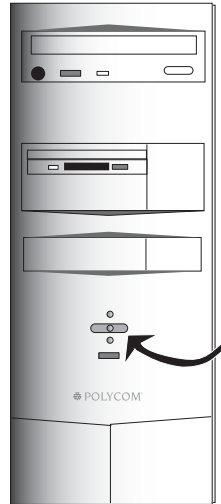

Main Camera

iPower 9000 System

The iPower 9000 system uses either the PowerCam™ Plus or the PowerCam as its standard main camera. You can also use either camera as an auxiliary camera.

The PowerCam Plus features the Automatic Camera Pointing (ACP) mechanism. When you enable ACP, the camera uses the built-in ACP microphone to automatically locate and frame the speaker.

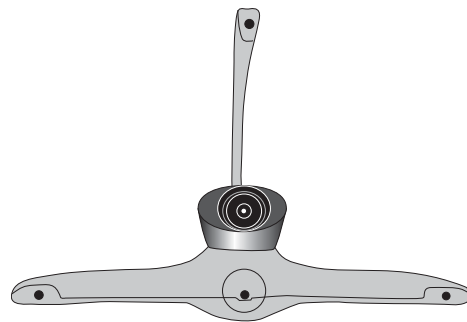

PowerCam Plus

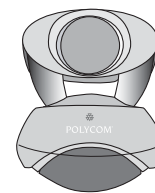

PowerCam

iPower 600 System

The iPower 600 system uses the Camera and Microphone module as its standard main camera and microphone.

The standard main camera is a pan-tilt-zoom (PTZ) camera, which utilizes the Automatic Camera Pointing (ACP) mechanism. The Camera and Microphone module also includes the Zoom Mic.

You must power off the system to connect or disconnect the Camera and Microphone module.

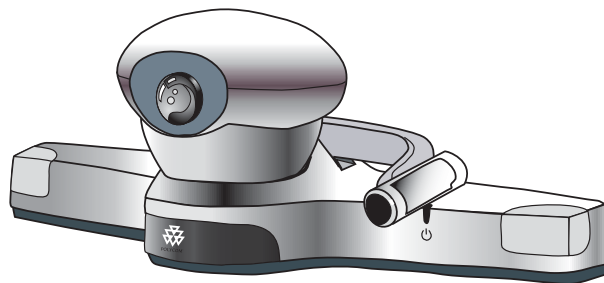

iPower 900 System

The iPower 900 system uses either the iPower 80 Dynamic Locating Camera or the iPower 70 Room Camera as its standard main camera.

The iPower 80 features the Automatic Camera Pointing (ACP) mechanism.

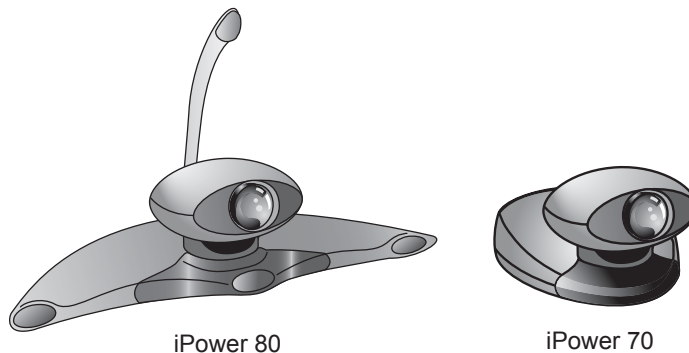

Remote Control Devices

iPower 9000 System

You can use the iPower 9000 system keyboard for both administrative and user tasks. It includes the standard keyboard character keys, an integrated trackball,

and buttons that correspond to common user tasks. For information about how to use the buttons on the keyboard, see the *iPower 9000 Collaboration System Quick Tips Sheet*.

The remote control is designed to make video collaboration easier. The buttons on the remote correspond to common tasks that you perform during a video collaboration meeting, such as making a call and zooming the camera.

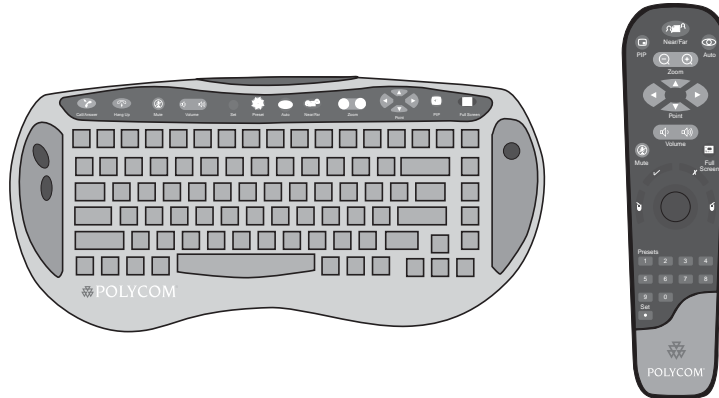

iPower 600 and iPower 900 Systems

You can use the keyboard for the iPower 600 and iPower 900 systems for both administrative and user tasks. It includes the standard keyboard character buttons and an integrated trackball; however, it does not include buttons that correspond to common user tasks.

Like the remote control for the iPower 9000 system, the buttons on the remote control for the iPower 600 and iPower 900 correspond to common tasks that you perform during a video collaboration meeting, such as making a call and zooming the camera. For information about how to use the buttons on the remote control, see the *iPower Collaboration System Quick Tips Sheet*.



PowerMic

All the iPower systems use the PowerMic™ as the main microphone. You can use up to a total of eight PowerMic microphones with your iPower 9000, and up to four with your iPower 600 and iPower 900.

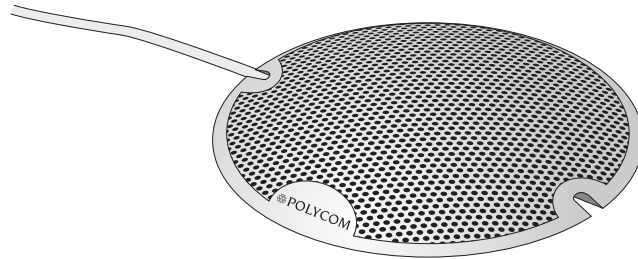

ImageShare or ImageShare II

iPower 9000 and iPower 600 Systems

The ImageShare II device makes it easy for you to add audio and video from a laptop to your system.

The ImageShare II is included with the iPower 9000 system and is available as an option for the iPower 600 system.



iPower 900 System

The ImageShare device makes it easy for you to add audio and video input and output devices, such as a laptop or a projector, to the iPower 900 system.

The ImageShare is included with the iPower 970 system and is available as an option for the iPower 960 system.



Optional Hardware Components

The following hardware components can be purchased separately:

- Display
- Cart
- Additional cameras
- Other optional hardware components

Display

The display shows video from the cameras and other video sources, application windows, online help, and so on. The display can be a regular display or a flat-panel display, and you can have up to two displays connected to your system.

The display's picture-in-picture (PIP) window is an area on the screen that is usually used to show the image you are sending to the other call participants.

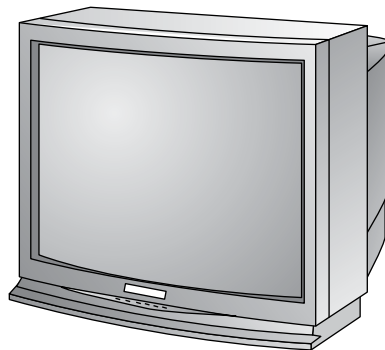

If your system has two displays, one must be an SVGA/XGA display and the other an NTSC/PAL display. In systems with two displays, you view People on the NTSC/PAL display and view Content, such as reports and presentations, on the SVGA/XGA display. Because you view People on the NTSC/PAL display, you should place the camera on that display.



Note

If you install a second display, you must open the AdminTools Monitor page and check the Use second monitor check box. See the AdminTools online help for more information. To access this help, press the  HELP button on the remote control, press F1 on the keyboard, or click Help when you are within the AdminTools application.

Cart

You can use one of several carts to hold the iPower system, display, peripheral devices, and documentation. The Premier Cart includes enclosed storage for your computer box, monitor, system components, and documentation. It also features a built-in Bose® speaker. The Utility Cart offers a more basic means to hold and move the system and display.

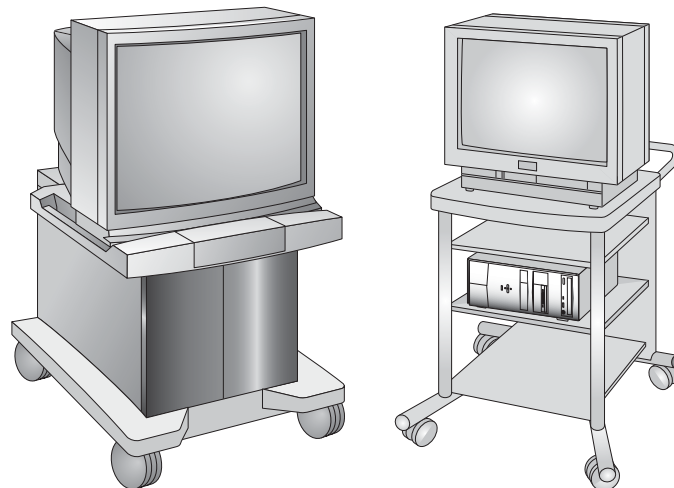

Additional Cameras

You can add additional cameras to your iPower system.

For the iPower 9000 and iPower 900 systems, you can use up to three cameras: a main camera, an optional auxiliary camera, and an optional document camera.

For the iPower 600 system, you can use a camera other than the standard Camera and Microphone Module as the main camera. You can also add a document camera.

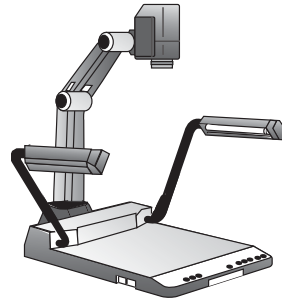

Document Camera

VCR

You can add one or two VCRs to any of the iPower systems so that users can play videotapes during calls or create videotapes of meetings.



Note

If you install one or two VCRs, you must open the AdminTools Camera Controls and VCR page and click either One VCR or Two VCRs. See the AdminTools online help for more information. To access this help, press the ⓘ HELP button on the remote control, press F1 on the keyboard, or click Help when you are within the AdminTools application.

Other Optional Hardware Components

There are several other optional components you can add to the iPower systems:

- Remote control devices — You can add your own keyboard, mouse, or remote control to any of the iPower systems.
- USB devices — You can add a USB device, such as a printer or a scanner, to the iPower 9000 and iPower 600 systems, or to version 3.0 or higher of the iPower 900 system.
- Serial devices — You can add a serial device, such as a whiteboard, to any of the iPower systems. You can also add a custom control panel to the iPower 9000 system.

- Room audio input devices — Instead of a second PowerMic, you can add a room audio input device, such as a Polycom Vortex® device, to the iPower 9000 system.
- Look-At-Me-Button™ (LAMB™) — You can enable people who are not near the keyboard or remote control to move the camera by adding LAMBs to the iPower 600 and iPower 900 systems.
- Projector — You can connect a projector to the back of an iPower 9000 or iPower 600 system or to the ImageShare device on an iPower 900 system. Depending on your system, you may need to provide your own VGA splitter.
- Headset — You can connect a headset with earphones and microphones to an iPower 600 system. The headset plugs into the side of the computer unit, behind the power button. You can also connect a headset to an iPower 9000 system, but you must provide your own an RCA-to-phone adapter cable.
- Laptop — You can add laptop (or PC) audio output to your system by connecting a laptop to the ImageShare or ImageShare II device, and then connecting the ImageShare or ImageShare II to your system's computer box. Or, with the iPower 600, you can directly connect a laptop to the computer unit; however, you must provide your own audio and VGA cables.

Standard Software Applications

The software applications listed in the following table are included on the Polycom *System Software* CD.

You can find many of these applications by choosing Programs>iPower from the Start menu.

This application...	Enables you to...
Setup Wizard	Easily install the Collaboration software onto your system.
Collaboration application	Participate in videoconferences or in-room presentations.
AdminTools	Configure and maintain the iPower collaboration system.
Operating Statistics	Verify system performance, view a log of call-related statistics and events, log system events, and run loopback tests.
Hardware Diagnostics	Test the performance of the system's internal boards and cables, and monitor input and output from audio and video devices that are connected to the system.
File Transfer	Send and receive files during meetings.
NetMeeting® Chat	Use text chatting while you are in a call.

This application...	Enables you to...
Acrobat Reader	Read user documents provided in PDF format.
Microsoft® Office Viewer	View documents from Windows® applications, such as PowerPoint® and Excel.

Optional Software Applications

The software applications listed in the following table are optional.

This application...	Enables you to...
Document Server	Store files on a server so they can be retrieved during meetings.
Directory Services Setup	Set up and access Central and Personal Directories, or “phone books,” of collaboration sites.
Network Manager	Manage networked collaboration systems.
PathNavigator Conference-on-Demand	Make a multipoint call in a single step by selecting multiple ISDN and LAN addresses from a single directory or by entering multiple addresses in the Make a Call dialog box.
Global Management System	Monitor general system information such as network interface status and call status, receive notification when an iPower user needs help, and send and receive messages from users.
WebOffice	Conduct online meetings and share information, files, applications, or documents with other WebOffice users.

2

AdminTools Roadmap

AdminTools is a utility available with each iPower system. You use AdminTools to initially set up the system. Thereafter, you may want to use this utility to fine-tune the system and to make adjustments according to your organization's video collaboration needs.

This chapter provides a roadmap of all the tasks you can do using AdminTools. It includes these topics:

- Customizing the System
- Setting Up System Security
- Configuring Network Use
- Configuring Audio
- Configuring Video
- Configuring Streaming
- Setting Up Directories
- Allowing Data Sharing
- Maintaining the System
- Using Remote Management Tools
- Configuring Multipoint Conferencing













Note

For complete information about any of these tasks, view the AdminTools help. To access this help, press the ⓘ HELP button on the remote control, press F1 on the keyboard, or click Help when you are within the AdminTools application.







To access AdminTools:

Choose Start>Programs>Polycom iPower>Administrator Information>AdminTools.











Customizing the System

To Do This...	First Click...	Then Click...
Change the second monitor's PIP position	 Video	Monitor tab
Configure Standby Mode	 General	Logoff and Standby tab
Set call preferences, such as how incoming calls are answered or how the redial function works	 General	Call Preferences tab
Allow use of a custom control panel	 Utilities	Custom Control tab
Provide a site name	 General	System Information tab
List a name and number to call for help	 General	System Information tab
Add applications to the Options menu	 General	Options Menu Configuration tab
Add applications to the People and Content list	 General	People and Content List Configuration tab
Configure Quality of Service (QoS) on an iPower 9000 system	 LAN	QoS tab
Configure WebOffice for an iPower system	 Utilities	WebOffice tab





Setting Up System Security

To Do This...	First Click...	Then Click...
Configure the Adapter/NAT/Port Range	 LAN	Adapter/NAT/Port Range tab
Save numbers in a Call Log	 General	Call Preferences tab
Choose the logon method	 General	Logon and Security tab
Disable Auto Logon	 General	Logon and Security tab
Set the logoff options	 General	Logoff and Standby tab
Lock settings on a page	 General	Locked Settings tab









Configuring Network Use

To Do This...	First click...	Then click...
Set the basic ISDN configuration	 ISDN	ISDN Configuration tab
Set the ISDN bandwidth options	 ISDN	ISDN Bandwidth tab
Set the advanced ISDN configuration	 ISDN	ISDN Configuration tab
Configure the system to use an IMUX (iPower 9000 and iPower 900 systems)	 ISDN	IMUX Setup tab
Reserve a line for voice calls	 ISDN	Set Up ISDN button
Reserve a line for remote management	 ISDN	ISDN Bandwidth tab
Set the basic LAN configuration	 LAN	LAN Configuration tab
Set the LAN bandwidth options	 LAN	LAN Bandwidth tab
Set up a gateway	 ISDN	Gateway Setup tab
Set up a gatekeeper	 LAN	Gatekeeper Setup tab



Configuring Audio

To Do This...	First Click...	Then Click...
Set the audio algorithm for ISDN calls	 Audio	Audio Preferences tab
Set the audio algorithm for LAN calls	 Audio	Audio Preferences tab
Configure Automatic Gain Control (AGC) for auxiliary audio	 Audio	Audio Input and Output tab
Configure the microphones	 Audio	Audio Input and Output tab
Define the number of speakers	 Audio	Audio Input and Output tab



Configuring Video

To Do This...	First Click...	Then Click...
Set the video algorithm for ISDN calls	 Video	Video Preferences tab
Set the video algorithm for LAN calls	 Video	Video Preferences tab
Enable flicker reduction	 Video	Video Preferences tab
Enable or disable dual images	 Video	Video Preferences tab
Set up cameras and video sources	 Video	Cameras and Video Sources tab
Configure camera behavior	 Video	Camera Control and VCR tab
Add a second monitor	 General	Monitor tab
Add VCR(s)	 Video	Camera Control and VCR tab



Configuring Streaming

To Do This...	First Click...	Then Click...
Configure the Streaming option on an iPower system	 LAN	Streaming tab
Configure the Streaming option on an external server	 LAN	Streaming tab



Setting Up Directories

To Do This...	First Click...	Then Click...
Set up a Local Directory	 Directory	Local Directory tab
Set up a Central Directory	 Directory	Central Directory Server Setup tab
Register with an ILS server	 Directory	ILS Registration tab





Allowing Data Sharing

To Do This...	First Click...	Then Click...
Allow file transfer	 Utilities	File Transfer tab
Configure the system to use a Document Server	 Utilities	Document Server tab



Maintaining the System

To Do This...	First Click...	Then Click...
Update the system information	 General	System Information tab
Set up Readiness Monitoring	 Utilities	Readiness Monitoring tab

Using Remote Management Tools

To Do This...	First Click...	Then Click...
Configure the system for WebRemote management	 Utilities	Network Management tab
Set up RAS access over ISDN	 ISDN	ISDN Bandwidth tab
Configure the system for SNMP management	 Utilities	Network Management tab
Set up the Global Management System on an iPower system	 Utilities	Global Management System tab
Disable the Global Management System on an iPower system	 Utilities	Global Management System tab

Configuring Multipoint Conferencing

To Do This...	Click...
Allow multipoint conferences	 Multipoint
Set the default video display for internal multipoint	 Multipoint
Set the audio and video preferences for internal multipoint	 Multipoint

3

Tips for Tasks You Do Rarely

This chapter provides information about tasks that you need to perform only once or very rarely. It includes these topics:

- Setting Up the Log On Process** — Describes how to choose logon options and set up user accounts.
- Setting Up Additional Software** — Describes additional software that you may install with your system, such as remote management software, Document Servers, PathNavigator Conference-on-Demand, and the Polycom Global Management System.
- Restoring the System** — Describes how to reinstall the iPower system software.

Setting Up the Log On Process

To control how users access the iPower system, you must decide which logon options to use.

Choosing Logon Options

The iPower system offers two logon options:

- Standard Windows logon** lets users log on by entering a valid user or administrator name and password for either a local Windows user account or a Windows domain account. After they log on, users have the privileges you define for the local Windows user account or Windows domain account.
- Auto Logon** lets users log on to the iPower system using the default user account. With the Auto Logon feature, the Logon dialog box appears with the default user name and password already filled in. Therefore, users don't have to log on using their own accounts, and they all have the privileges defined for

the default user account. Auto Logon is the default logon option for the iPower system.

Setting Up User Accounts for Standard Windows Logon

The available user accounts are as follows:

Type of Account	Description	How to Create This Account
Local user account	Requires a unique account for each user, which allows the user to access the system.	Use the Windows User Manager to create local user accounts. For specific instructions, see your Windows documentation.
Domain account	Requires a unique account for each user, which allows the user to access each system in the domain.	Use the Windows User Manager for Domains to create domain accounts. For specific instructions, see your Windows documentation.
iPower system default user account	Allows all users to access the system. The default user name and password appear in the Logon dialog box.	Use the AdminTools Logon and Security page to set up the iPower system default user account. Set the default user name and password using the Default User Account section of this page.

Setting Up Additional Software

This section describes additional software that you may have added to the iPower system, such as remote management software, Document Servers, PathNavigator Conference-on-Demand, and Polycom WebOffice.

Remote Management Software

Three remote management software applications are available with the iPower system: WebRemote, SNMP Management, and the Polycom Global Management System.

WebRemote

Before you use WebRemote, you must configure your iPower system to use it. If you plan to perform network management of the iPower system, but your network management station (NMS) is not connected to the system via a LAN, you may also need to set up RAS access over ISDN.

For information about how to configure the system to use WebRemote and how to set up RAS access over ISDN, see the AdminTools online help. To access this help, press the  HELP button on the remote control, press F1 on the keyboard, or click Help when you are within the AdminTools application.

WebRemote also requires you to log on with an administrator account and to have one of the following browsers:

- Microsoft Internet Explorer 5.0 or higher
- Netscape® Navigator 4.6 or higher

To use WebRemote:

1. Launch your web browser.
2. Enter the system's IP address or DNS name.
A web page opens.
3. Click WebRemote.
4. Enter a user name and password for an account that has administrator privileges on the iPower system.
WebRemote opens.
5. Use WebRemote as follows:

Click...	To...
Call Control	Access the iPower system Collaboration application.
AdminTools	Access the AdminTools application.
Diagnostics	Access the Hardware Diagnostics application to perform tests and download error log files.
System State	View Readiness Monitoring error messages, shut down the iPower system applications, or restart the system.
Statistics	View the system statistics.
Alarms	View SNMP alarms.
Help	Access WebRemote online help.

For more information about WebRemote, see the WebRemote online help.

SNMP Management

To enable SNMP management, you must do the following:

1. Set up an SNMP environment.

To set up an SNMP environment, you must install network management software (such as HP® OpenView) on the computer you intend to use as your network management station (NMS). You cannot use the iPower system as the NMS.

2. Install the iPower MIBs:

a. Access the appropriate iPower system MIB file at one of these locations:

- On the iPower system at C:\Program Files\PictureTel\VCSS\SNMPMib.
- From the Polycom web site at www.polycom.com.

b. Install the MIBs on the network management station as required by your management software.

For more information, see the management application's documentation.

c. Using AdminTools, configure the iPower system for SNMP management.

For more information, see the AdminTools online help. To access this help, press the  HELP button on the remote control, press F1 on the keyboard, or click Help when you are within the AdminTools application.

3. Add the iPower Network Manager.

Once you've configured the iPower system to allow remote management via SNMP, you may choose to use the iPower Network Manager application, which is available on the *iPower Network Manager* CD. This optional application enhances HP OpenView or other network management software.

For information on how to use the iPower Network Manager application, see the Network Manager online help. For information on how to use your SNMP network management application to control a remote system, see the documentation that came with the application.

Global Management System

The Polycom Global Management System is a web-based software application that provides centralized video network management. As long as you have a web browser, you can use the Global Management System with the iPower system to monitor and maintain local and remote videoconferencing systems and networks from anywhere in the world.

You can use the Global Management System with the iPower system to:

- Monitor system status
- Obtain general system information and addresses

- Provide Remote Alert Notification
- Obtain Call Detail Record information, such as call time, start and end time, video bandwidth, and number dialed
- Configure videoconferencing equipment
- Update iPower software
- Send messages to the Network Administrator

In order to use the Global Management System with an iPower system, you must set up the Global Management System user account on an iPower system. To do this:

1. Start AdminTools and click  Utilities.
2. Click the Global Management System tab.
3. Check the Allow Management via Global Management System check box.
4. Click Set Password.
5. Enter a password to access the iPower system from the Global Management system.

To disable the Global Management System on an iPower system:

1. Start AdminTools and click  Utilities.
2. Click the Global Management System tab.
3. Uncheck the Allow Management via Global Management System check box.
The password used to access the iPower system is not affected.

To remove a Global Management System IP address:

1. Start AdminTools and click  Utilities.
2. Click the Global Management System tab.
3. In the Global Management System Station URLs list, highlight the IP address that you want to remove.
4. Click Remove.

When you enable the Global Management System, you can designate the Polycom Global Directory as one of the Central Directories. For more information about this and about the Global Management System in general, see the Global Management System documentation.

Document Servers

A Document Server provides several advantages, such as:

- Flexibility.** Users aren't hindered by the space limitations imposed by diskettes.
- Frees hard drive space.** Users store the files they intend to share on the server, not on the iPower system.
- Security.** User data is secure. Each user's access to the server is limited to an individual folder created at logon.

To set up a Document Server, you must install the server software on a Windows NT® server and then configure the iPower system to use it. The server must meet these requirements:

- Microsoft Internet Information Server (IIS) version 4.0 or higher
- Microsoft Windows NT Server 4.0 or higher with Service Pack 3 or higher
- An NTFS partition
- 90 MHz or faster Intel® Pentium processor
- 64 MB of RAM
- 10 MB of hard drive disk space per user

To install the Document Server software:

1. Log on to the system you intend to use as the server.
2. Insert the *iPower Document Server* CD into the CD-ROM drive.
3. Double-click the CD-ROM drive icon and then double-click the Install Document Server icon.
4. Follow the onscreen instructions to complete the installation.
5. Using AdminTools, configure how your users utilize the Document Server. For additional information, see the AdminTools online help. To access this help, press the  HELP button on the remote control, press F1 on the keyboard, or click Help when you are within the AdminTools application.



Note

If You Allow Document Server Use...

- Check that users have Microsoft Internet Explorer version 4.0 or higher or Netscape Navigator version 4.0 or higher installed on their desktop computers.
 - Publish the Document Server URL(s) throughout your organization.
 - Customize the Document Server logon message to suit your collaboration environment. To customize the message, edit the Welcome.txt file at C:\inetpub\wwwroot\documentserver\ on the Document Server.
 - Maintain user permissions for the Document Server so that unauthorized individuals can't access other people's accounts.
 - Install a virus protection package and keep it updated with the latest definitions.
-

PathNavigator Conference-on-Demand

PathNavigator Conference-on-Demand works in conjunction with a Polycom PathNavigator call processing server and allows users to:

- Select multiple ISDN and LAN addresses from a single directory to make a multipoint call in a single step.
- Enter multiple addresses manually in the Make a Call dialog box to make a multipoint call in a single step.
- Use the ISDN Callback feature, which dials all participants designated for a multipoint videoconference.
- Save multiple dialing addresses as a single entry.



Note

If both PathNavigator Conference-on-Demand and the iPower Internal Multipoint option are available for multipoint calls, the iPower system uses PathNavigator Conference-on-Demand.

To configure PathNavigator Conference-on-Demand:

1. Start AdminTools and click  LAN.
2. Click the Gatekeeper Setup tab.

3. Click the Use a gatekeeper option.
4. In the Gatekeeper DNS name or IP address field, enter the PathNavigator gatekeeper DNS name or IP address.
5. Enter the video call alias and voice call alias in the appropriate fields. The video call and voice call aliases must be unique.
6. Click OK.
7. Configure PathNavigator for the Conference-on-Demand feature.
For more information about using PathNavigator Conference-on-Demand with the iPower system, see the AdminTools online help. For more information on how to configure PathNavigator Conference-on-Demand, see the PathNavigator documentation.



Note

The default profile as defined in PathNavigator includes the line rate, the T.120 rate, and video session information. In this release, you cannot modify this information.

To place a call using PathNavigator Conference-on-Demand:

1. Access the iPower Collaboration application.
2. Click Make a Call.
3. Click Directory.
4. Click on each number that you want to dial.
A check mark appears next to the number. You can select as many numbers as your bridge supports. You can also enter numbers manually, separated by commas.
5. Click OK to place the call.
For more information about placing a call using PathNavigator Conference-on-Demand, see the Collaboration help. To access the Collaboration help, press the ⓘ HELP button on the remote control, press F1 on the keyboard, or click Help when you are within the Collaboration application.

WebOffice

Polycom WebOffice enables iPower users to use their web browsers to conduct online meetings and to share information, files, applications, or documents with other WebOffice users. WebOffice also provides instant messaging capabilities.

In order to use WebOffice on the iPower system, you must set up a WebOffice account for the iPower system on a separate WebOffice server. Once you do this, anyone who uses the iPower system can also use WebOffice to share information with other WebOffice users on the server. Users do not need to be in a call to share information; they need only to log into the iPower account on the WebOffice server.

To set up a WebOffice account for the iPower system on the WebOffice server:

1. Start AdminTools and click  Utilities.
2. Click the WebOffice tab.
3. Check the Use Polycom WebOffice check box.
4. Enter the WebOffice information:
 - a. Enter the name or web address of the WebOffice server in the WebOffice Server Name or URL field (for example, weboffice.mycompany.com).
 - b. Enter the name of the WebOffice account in the Unique system name field (for example, iPower80).

To easily identify the WebOffice account for the iPower system, use a name associated with the iPower system, such as the system name or the room where the system is located.
 - c. Enter the company internet address in the Domain name of company or organization field (for example, mycompany.com).

The office name, which is based on the system name and domain name, then automatically appears in the Office name field. The office name is always in email address format (for example, iPower80@mycompany.com).
 - d. If your WebOffice service is configured to require a registration key, you must enter a valid key in the Registration Key (if required) field.

For more information, contact your WebOffice server administrator.
5. Click Create Office.
6. Confirm the password that you specified.

To access WebOffice from an iPower system:

Click on the WebOffice icon on the desktop.

Restoring the System

When you restore the iPower system, the system is returned to its original factory state. You should only restore the system when directed by a Polycom support representative.

For a list of system default settings, see Appendix A, “System Default Settings.”

Getting Ready to Reinstall

Before you reinstall your system software:

1. Back up the Local Directory data.
Save your Local Directory data by copying
C:\Program Files\PictureTel\vcs\tsdir.ini to external media.
2. Record the configuration settings.
Make a record of your configuration settings by running the iPower Operating Statistics utility. On the Configuration Summary page, click Save As to save the file iPowerSysConfigLog.txt to external media. You can use this information to help reconfigure the system after you reinstall the software.
3. Make sure you have the system serial number and your LAN and ISDN settings.
The serial number is printed on the back of the computer box.

Reinstalling the iPower System

When you *reinstall* your iPower system software, any Directory entries and customized settings you have entered are lost, and any additional software is erased, including system upgrades that you may have applied. (When you *install upgrades* to the system, Directory entries are retained and any additional software you may have installed is not erased.)



Note

The iPower system software does not provide an uninstall program to remove the system software. However, reinstalling the system software will overwrite all of the files created and installed during the original installation.

iPower 9000 and iPower 900 Systems

To reinstall an iPower 9000 or iPower 900 system:

1. Do one of the following:
 - For iPower 9000 systems, insert the CD marked *Disk 1 of 2* into the CD-ROM drive, and then power on the system.
 - For iPower 900 systems, insert the boot diskette into the diskette drive and the CD marked *Disk 1 of 2* into the CD-ROM drive, and then power on the system.
2. When you see the following dialog box, choose a language for the installation and press OK. (Note that the text in this dialog box may be in English, even if your system is running in another language.)

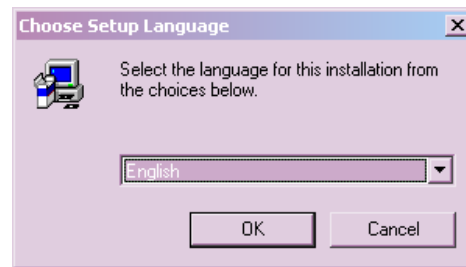

3. Insert the CD marked *Disk 2 of 2* when you see this dialog box instructing you to insert the next media:

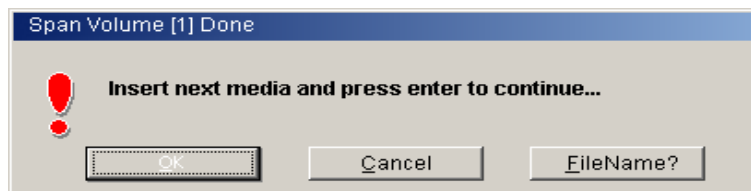

Press Enter after you insert the second CD.

4. Follow the instructions on the screen, and restart the system to complete the reinstallation.
If the system does not restart automatically after completing the upgrade, you must restart it manually.
5. Copy your Local Directory data back to C:\Program Files\PictureTel\vc\tsdir.ini.

iPower 600 System

To reinstall an iPower 600 system:

1. Power off the iPower 600 system.

2. From the Windows desktop, right-click the My Computer icon and select Properties.
3. Click the Advanced tab and then choose Startup and Recovery.
4. Check the Display list of Operating Systems for 30 seconds check box and then click Apply.
5. Restart the system.
6. Select Factory Default Reload and press Enter.
If Factory Default Reload does not appear, choose Return to OS Choices Menu, and then choose Factory Default Reload.
7. When you see the following dialog box, choose a language for the installation and press OK. (Note that the text in this dialog box may be in English, even if your system is running in another language.)



8. Follow the onscreen instructions to complete the reinstallation.
9. Copy your Local Directory data back to C:\Program Files\PictureTel\vc\tsdir.ini.

4

Tips for Tasks You Do Regularly

This chapter provides information about tasks that you need to perform on a regular basis. It includes these topics:

- ❑ Adding Applications — Provides information about adding software applications to the iPower system.
- ❑ Monitoring System Statistics — Describes how to view system statistics using the Operating Statistics application and the Conference Statistics screen.
- ❑ Accessing and Viewing Logs — Lists the log files available from Operating Statistics, Hardware Diagnostics, and Windows.
- ❑ Setting Up Virus Protection — Provides information on protecting the iPower system from computer viruses.
- ❑ Conserving Disk Space — Provides information on saving space on the iPower hard drive.

Adding Applications

To extend your users' collaboration effectiveness, install the software applications you think users will use most often to create or edit documents.

For the iPower 600, install applications on the D: drive to conserve space on the C: drive.

To install software applications, follow the same procedure as you would to install a software application on a typical PC running Microsoft Windows. For specific instructions, see the Windows documentation.

Monitoring System Statistics

The Operating Statistics application and the Conference Statistics screen allow you to view a wide variety of statistics on the system's performance during calls. You can also view these statistics using SNMP Management, WebRemote, and the Polycom Global Management System.



Note

The Operating Statistics and Collaboration applications may be run simultaneously, whereas the AdminTools and Collaboration applications *cannot* be run simultaneously.

Viewing Detailed System Statistics

Use the Operating Statistics application to track detailed statistics on the video, audio, and network performance for the current or most recent call.

To start Operating Statistics:

1. Make sure the Collaboration application is running.

- Choose Start >Programs>Polycom iPower>Administrator Information>Operating Statistics.

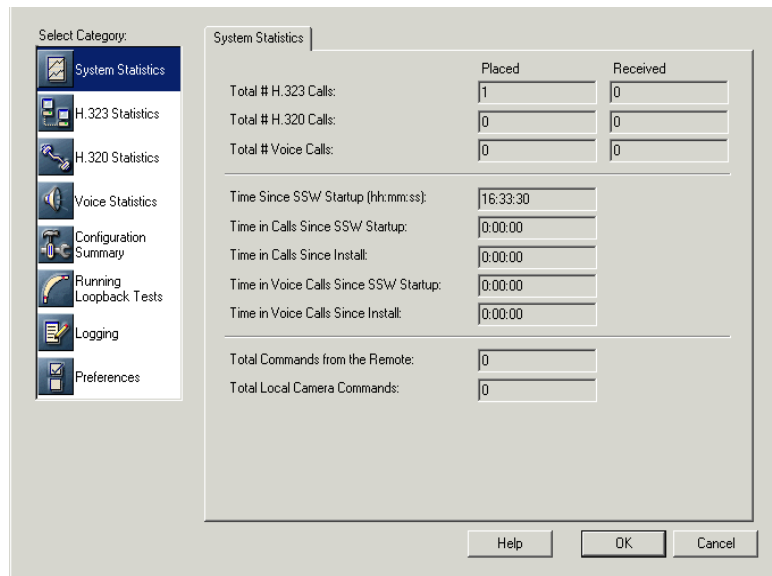

- Choose the category of statistics that you want to view.

Category	Description
System Statistics	Displays the total number of calls, total time of calls, and total number of remote control and camera commands issued.
H.323 Statistics	Displays information about H.323 calls on seven pages (State, Video, Audio, Video Channel, Audio Channel, Control Data, and Channel).
H.320 Statistics	Displays information about H.320 calls on six pages (State, Video, Video Errors, Audio, Channel, and Data).
Voice Statistics	Displays information about voice calls.
Configuration Summary	Displays summary information about the configuration on seven pages (General, ISDN, LAN, Video, Audio, Directory, and Utilities).
Running Loopback Tests	Displays a list of loopback tests available to run.
Logging	Displays information about the Call Log and the System Logs.
Preferences	Displays preferences that can be set by the system administrator.

Viewing the Configuration Summary

You can view the system configuration settings using the Configuration Summary page in the Operating Statistics application.

To view the system configuration:

1. Choose Start >Programs>Polycom iPower>Administrator Information>Operating Statistics.
2. Click  Configuration Summary.

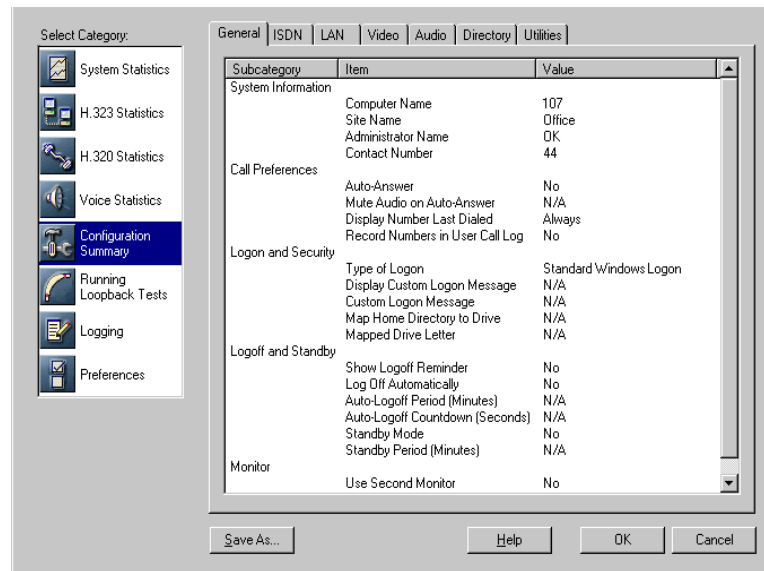

3. Choose a tab to view detailed information.

Page	Description
General	Provides details related to System Information, Call Preferences, Logon and Security, Logoff and Standby, and Monitor.
ISDN	Provides details related to ISDN, Advanced ISDN Configuration, ISDN Bandwidth, ISDN Setup, IMUX Setup, and Gateway Setup.
LAN	Provides details related to LAN Configuration, Gatekeeper Setup, and LAN Bandwidth.
Video	Provides details related to Video Preferences and Camera and Video Sources.
Audio	Provides details related to Audio Preferences and Audio Inputs.

Page	Description
Directory	Provides details related to Directory Options, Central Directory Server Setup, and ILS Registration.
Utilities	Provides details related to Document Server, File Transfer, Readiness, and Network Management.
Internal Multipoint	Provides details related to Internal Multipoint, such as the key code, audio preference, video algorithm, and maximum video frame rate.

Viewing Statistics for the Current Call

The Conference Statistics screen provides general information on system performance for the current call.

To display the Conference Statistics screen:

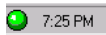
Double-click the round  Conference Statistics icon in the Windows system tray at the bottom of the screen.



Accessing and Viewing Logs

A number of log files are available for your use.

From Operating Statistics:

- Call Log — Tracks general information on all of the calls made and answered by the system. From Operating Statistics, you can view the statistics and save the log as a text file to the location you specify.
- System Logs (four logs) — Record a variety of technical information that can help you verify system performance and troubleshoot problems. The System Detailed Log, ISDN Log, and BAS Codes Log files are located at C:\DiagLogFile.ptl, C:\ISDNLog.log, and C:\BASCodesLog.log. You can start and stop these logs from Operating Statistics. A log containing a subset of the information in the System Detailed Log is located at C:\SysLogFile.ptl and is designed to be copied onto a diskette.
- Configuration Summary — Lists the specific system settings configured through the AdminTools application. From Operating Statistics, you can view the settings and save them as a text file to the location you specify and with a file name you specify. The default file name is iPowerSysConfigLog.txt. Polycom recommends that you save this information electronically as a text file and then print and save it for future reference.

From Hardware Diagnostics:

- Hardware Diagnostics Error Log — Tracks information generated by the Hardware Diagnostics application. This log file is designed to be copied onto a diskette and then sent to Polycom for analysis, should you encounter problems you can't resolve. This log is intended for use by Polycom, not end users. It is located at C:\Program Files\PictureTel\VCS\Diagnostics>ErrorLog.txt.

From Windows:

- System, Security, and Application logs — Track system, security, and application events. Use Microsoft Event Viewer to view and manage these event logs.

Setting Up Virus Protection

Although infection from a computer virus is rare, you should be aware that the iPower system is a PC-based product and is therefore susceptible to virus infection.

To ensure the security of your system, take these precautions:

- Make sure that all accounts use effective passwords, especially accounts with administrative privileges.
- Install, update, and use anti-virus software.
- Install the latest security updates for Windows and for any applications you install.
- Activate auditing for Windows events and monitor the audit log.
- Restrict anonymous logins.
- Conduct periodic reviews of your system. The Microsoft Personal Security Advisor (available free at <http://www.microsoft.com/technet/security/tools/tools.asp>), can assist you in this review.
- Check with your network administrator for security procedures.



Note

The iPower 900 system version 3.0.0 or higher and all versions of the iPower 9000 and iPower 600 system use the multi-language version of Windows 2000. When you download language-specific Microsoft patches, always use the English-language version even if you run your system in another language.

Conserving Disk Space

You should conserve space on the iPower hard drive by periodically checking for and eliminating unwanted files or applications. This is particularly important if many users access the system.

On the iPower 9000 and iPower 900, users install their own applications, such as Microsoft Office, on the C: drive. On the iPower 600, users install their own applications on the D: drive.

Check for unwanted files in the following places:

- Received files
- Document Server documents
- Documents placed on the hard drive

5

Tips for Helping Users

This chapter provides information that you can use to help the iPower users in your organization. It includes these topics:

- ❑ **Making Sure Users Have the Information They Need** — Explains how you can use the *Quick Tips Sheet* and *Getting Started Guide* to provide users with information. Also explains how to change the room information that appears on the iPower system home page.
- ❑ **Making Sure Users Know How to Contact the System Administrator** — Lists various ways that you can inform users about how to contact you.
- ❑ **Finding Information in the Documentation** — Provides a list of the iPower documentation, briefly describes it, and tells where to find it.

Making Sure Users Have the Information They Need

Providing information to the users enables them to begin using the iPower system more quickly and reduces their need to get help from you or other resources.

Sending the “Quick Tips Sheet” to Users

The *iPower Collaboration System Quick Tips Sheet* provides basic system information that users can quickly refer to when using the iPower system.

This sheet is available as a PDF file on the *iPower Documentation CD*. Polycom encourages you to send this PDF file by email to video collaboration users throughout your organization. Users can then print out the file and bring it with them whenever they make a video call. You may also want to print it out and leave a few copies in each conference room that is equipped with an iPower system.

Customizing the “Getting Started Guide”

Each iPower system comes with an online user’s guide, the *iPower Collaboration System Getting Started Guide*. This guide is available as a .doc file.

Since iPower system options can vary, the *Getting Started Guide* is somewhat generic. To make the guide as useful as possible for your users, you should customize the original Microsoft Word version of this document according to your particular collaboration environment.

At a minimum, Polycom recommends that you add information that is specific to your site in the “Site Info” section, such as a name and phone number for users to call if they have trouble using the system.

After you customize the *Getting Started Guide* using Word, you may want to make a PDF version available to your users. You could, for example, send it to your users by email or put it on your organization’s intranet. This way, users can view or print the document when they’re away from the system to prepare for when they use the system.

To edit the *Getting Started Guide*:

1. Locate and open the Microsoft Word version of the *Getting Started Guide* document.

The file is located on the *iPower Documentation Library* CD.

2. Use Microsoft Word to customize the document to meet your users’ needs.
3. Save the document as GetStart.pdf and distribute it to your users.

Displaying Room Information on the iPower System Home Page

The iPower system home page provides access to WebRemote, WebOffice, and WebStreaming. This page also displays information about the room in which the iPower system is located. You can enter this room information using the InputText.txt file.

Each line of the InputText.txt file contains a field name and a text string. You can enter information in the text strings. This information, along with the field names, appear on the iPower system home page. Even if you do not enter any text, the field names still appear.

To display room information on the iPower system home page:

1. Open the InputText.txt file at C:\Program Files\PictureTel\VCS\WebInterface\ConfigureMain.

2. Enter information about the room:

This field...	Lets you enter information about...	Such as...
RoomName	The name of the room where the iPower system resides.	<i>Bigelow or Main Conference Room</i>
RoomNumber	The room number, if any.	<i>105 or 29A</i>
RoomSize	The size of the room.	<i>20 seats or 20' x 40'</i>
AvailableEquipment	The equipment available in the room.	<i>Projector or VCR</i>
Location	The location of the room.	<i>Near the Cafeteria or Second Floor Lobby</i>
Extras	Any additional information that you want to include.	<i>You must reserve this room before using it or Not available on Mondays</i>
Imagename	An image, such as a logo, that appears as a thumbnail on the iPower system home page. When you click the thumbnail, the full-size image opens in a separate browser window.	<i>MapofBigelow.jpg or MainLogo.jpg</i>



Note

Do not change, delete, or add field names in the InputText.txt file. If you do, any text strings that you enter will not appear on the iPower system home page.

3. Save the InputText.txt file and the Imagename file in the Program Files\PictureTel\VCS\WebInterface\ConfigureMain directory. You cannot move these files to another directory.

Making Sure Users Know How to Contact the System Administrator

In case of problems or questions regarding the iPower system, users should be able to know where to find you, the system administrator.

To ensure that users can easily contact you:

- Add your name and number to the "Site Info" section of the *Getting Started Guide* and then distribute it to users.

See the previous section, “Customizing the Getting Started Guide,” for more information.

- ❑ Enter your name on the AdminTools System Information page.
See the AdminTools online help for more information.

Finding Information in the Documentation

This section contains information about the iPower documentation, such as the document titles and the purpose of each document. You can use this information yourself or use it to refer your users to the proper documentation.

You can find all the documents either on the *iPower Documentation* CD that came with your system or online. To access the online help systems, press the  HELP button on the remote control or click Help or press F1 on the keyboard when you are within the corresponding application.

If you need to....	Refer to....	Located on the....
Prepare for system installation by ordering ISDN, verifying requirements, and getting the network ready	<i>Preparing Your Network for Collaboration</i>	<i>iPower Documentation</i> CD
		Polycom web site at www.polycom.com
Observe regulatory information, notices, and approvals	<i>Product Regulatory Information</i>	<i>iPower Documentation</i> CD
		Polycom web site at www.polycom.com
Install the system hardware	<ul style="list-style-type: none"> • <i>Easy Install</i> Poster (for iPower 9000 or iPower 600) • <i>Installing the iPower 900 System</i> (for iPower 900) 	Hardcopy documentation
		<i>iPower Documentation</i> CD
		Polycom web site at www.polycom.com
Learn how to perform the tasks you need to get started with your system, learn what the system features are, and get tips on video collaboration	<i>Getting Started Guide</i>	<i>iPower Documentation</i> CD
		Polycom web site at www.polycom.com
Quickly obtain basic system information, such as which key to press on the keypad or how to make a simple video call	<i>Quick Tips Sheet</i>	<i>iPower Documentation</i> CD
		Polycom web site at www.polycom.com
Configure, maintain, and troubleshoot the system	<i>Tips and Troubleshooting</i>	<i>iPower Documentation</i> CD
		Polycom web site at www.polycom.com

If you need to....	Refer to....	Located on the....
Set up the PowerMic microphone	<ul style="list-style-type: none"> • <i>PowerMic Setup Sheet</i> (for quick setup) • <i>Installing the PowerMic</i> (for complete information) 	<i>iPower Documentation CD</i>
		Polycom web site at www.polycom.com
Install the PowerCam Plus camera	<i>PowerCam Plus Setup Sheet</i>	<i>iPower Documentation CD</i>
		Polycom web site at www.polycom.com
Install the iPower 80 camera	<i>Installing the iPower 80 Dynamic Locating Camera</i>	<i>iPower Documentation CD</i>
		Polycom web site at www.polycom.com
Install the iPower 70 camera	<i>Installing the iPower 70 Room Camera</i>	<i>iPower Documentation CD</i>
		Polycom web site at www.polycom.com
Install and use the ImageShare or ImageShare II device	<ul style="list-style-type: none"> • <i>ImageShare Setup Sheet</i> (for quick setup) • <i>ImageShare II Setup Sheet</i> (for quick setup) • <i>Installing and Using the ImageShare Devices</i> (for complete information) 	<i>iPower Documentation CD</i>
		Polycom web site at www.polycom.com
Set up the Premier Cart	<ul style="list-style-type: none"> • <i>Premier Cart Setup Sheet</i> (for quick setup) • <i>Installing a Collaboration System on a Premier Cart</i> (for complete information) 	<i>iPower Documentation CD</i>
		Polycom web site at www.polycom.com
Set up the Utility Cart	<ul style="list-style-type: none"> • <i>Utility Cart Setup Sheet</i> (for quick setup) • <i>Installing a Collaboration System on a Utility Cart</i> (for complete information) 	<i>iPower Documentation CD</i>
		Polycom web site at www.polycom.com
Install the Thin Display Adaptor	<i>Thin Display Adaptor Setup Sheet</i>	<i>iPower Documentation CD</i>
		Polycom web site at www.polycom.com
Install the iPower Executive system	<i>iPower Executive Setup Sheet</i>	<i>iPower Documentation CD</i>
		Polycom web site at www.polycom.com
License Microsoft 2000 for use	<i>Microsoft Windows 2000 Licensing Agreement</i>	Hardcopy documentation
Use AdminTools to configure and maintain the system	<i>AdminTools Help</i>	Online
Use the collaboration system to make and answer calls, share data, and so on	<i>Collaboration Help</i>	Online
Verify system performance	<i>Operating Statistics Help</i>	Online

If you need to....	Refer to....	Located on the....
Test the system hardware	<i>Hardware Diagnostics Help</i>	Online
Manage the system remotely	<i>WebRemote Help</i>	Online
Store data files and then access them during meetings	<i>iPower Document Server Help (optional)</i>	Online
Enhance remote SNMP management	<i>iPower Network Manager Help (optional)</i>	Online
Observe usage notes and other release information	<i>iPower Software Release Bulletin</i>	Polycom web site at www.polycom.com

6

Troubleshooting Tips

This chapter contains information about how to troubleshoot problems with the iPower system. For support or service, please contact your Polycom service provider or call Polycom Technical Support. You can find phone numbers for Technical Support in your area at the Polycom Web site, www.polycom.com.

This chapter includes the following topics:

- Solving Installation Problems
- Solving Startup Problems
- Solving General System Problems
- Solving Network Problems
- Solving Video Problems
- Solving Audio Problems
- Solving ImageShare and ImageShare II Problems

Solving Installation Problems

Problem	Corrective Action
First-time installation has failed	<ul style="list-style-type: none"> Make sure that all monitor, ImageShare device, infrared receiver, camera, and power cables are correctly installed and secure. (If necessary, consult the manual that came with your monitor.) Retry the installation.
Windows Wizard has failed	<ul style="list-style-type: none"> Perform standard PC debugging procedures.
iPower Setup Wizard has failed	<ul style="list-style-type: none"> View any error messages. From the Hardware Diagnostics application, start Automated Testing. If the test fails, call for service.

Solving Startup Problems

Problem	Corrective Action
System does not start	<ul style="list-style-type: none"> Check for bad hardware. <ul style="list-style-type: none"> From the Hardware Diagnostics application, start Automated Testing. If the test fails, call for service. Check the Windows Event Viewer, either on the local system or from a remote PC.
Splash screen is frozen	<div style="border: 1px solid black; padding: 5px; margin-bottom: 10px;">  <p>A splash screen that does not move indicates bad hardware.</p> </div> <p>Note</p> <ul style="list-style-type: none"> Restart the system. If the problem persists, call for service.

Solving General System Problems

Problem	Corrective Action
Parts of the system are not working	<ul style="list-style-type: none"> • Make sure that all cables are correctly installed and secure. • Make sure that all power cables are plugged into a power source (cart power strip, wall outlet, or uninterruptible power supply). • Make sure that the cart power strip or uninterruptible power supply is turned on. • Enable Readiness Monitoring in AdminTools. Address any warnings generated.
Keyboard is not working	<ul style="list-style-type: none"> • Make sure that the keyboard and remote control are not being used at the same time. You can't use both infrared devices simultaneously. • Make sure that keys on the keyboard are not being accidentally held down. • Make sure that the infrared path to the infrared receiver is not blocked. • Make sure that the infrared receiver is plugged in correctly. Make sure that the LED indicator on the front of the receiver is on when the system is on. • Make sure that the camera can detect the infrared signal. Get close to the camera, then point the keyboard at the camera. Watch the local video and see if flashing is visible from the keyboard. • Make sure that the keyboard contains fresh batteries. Check the keyboard batteries at least every two months.

Problem	Corrective Action
<p>Remote control is not working</p>	<ul style="list-style-type: none"> • Make sure that the keyboard and remote control are not being used at the same time. You can't use both infrared devices simultaneously. • Make sure that the infrared path from the remote control to the infrared receiver at the base of the main camera is not blocked. • Make sure that the remote control contains fresh batteries. <ul style="list-style-type: none"> - Check the remote control batteries at least every two months with the Hardware Diagnostics application. - Enable Readiness Monitoring in AdminTools. The iPower system will receive a message when the batteries are low. • Make sure that the camera can detect the infrared signal. Get close to the camera, then point the keyboard at the camera. Watch the local video and see if flashing is visible from the keyboard. • If the remote control still doesn't work, restart the system.
<p>ISDN or voice number is displayed incorrectly in the "To call this system" field</p>	<ul style="list-style-type: none"> • Make sure that your location information is correct. To correct the local area code or city code: <ul style="list-style-type: none"> - Choose Start>Settings>Control Panel>Telephony. - On the My Location page, type the correct code. - On the My Location page, in the I am in field, choose the country. - Click OK to close the Dialing Properties dialog box. • Enter your local numbers without the area code or city code, in AdminTools.



Solving Network Problems

Problem	Corrective Action
Readiness icon is displayed in the corner of the taskbar	<ul style="list-style-type: none"> • Double-click the exclamation mark icon in the system tray to view the Readiness message.
Readiness message: TCP/IP Connection Error: Network cable unplugged or network configured improperly	<ul style="list-style-type: none"> • Check the network cables to be sure that they are properly connected and secure. • Use the Windows Control Panel to check the TCP/IP settings. • Contact your network administrator.
Readiness message: ISDN cable is unplugged or the ISDN line is not active	<div style="border: 1px solid black; padding: 5px; margin-bottom: 10px;"> <p style="text-align: center;">_____</p>  <p>Note Use ISDN Readiness only in North America. Elsewhere, the network deactivates ISDN lines between calls, which will cause false Readiness messages.</p> <p style="text-align: center;">_____</p> </div> <ul style="list-style-type: none"> • Verify that the ISDN lines are connected and active. <ul style="list-style-type: none"> - From the Hardware Diagnostics application, click Test ISDN Lines. If a line does not reach the active state, make sure that it is connected properly. See the iPower installation documentation for information about how to connect ISDN lines. - If the ISDN lines activate, close the Hardware Diagnostics application and start the Collaboration application. - If you still see an ISDN Readiness condition and your switch type is DMS100, NI1, 5ESS G3, or 5ESS Multipoint, you may have a problem registering your SPIDs with the network. From the Operating Statistics application, check your ISDN configuration or contact your network provider. • Check the lights on the NT-1 boxes. Rapid blinking (8/second) usually indicates a network problem. Slow blinking (1/second) usually indicates an interface or videoconferencing error. • If the problem persists, check the provisioning of the line or contact the network administrator.

Problem	Corrective Action
<p>ISDN call attempt has failed; the user has received an error message <i>(continued on next page)</i></p>	<ul style="list-style-type: none"> • Perform those tasks specified in the error message. For example: <ul style="list-style-type: none"> - Check the dialed number. - Redial the call as “restricted”. - Ask the far end to call you. - Redial the call later. - Verify that the far-end system is working. - Contact the network provider. <hr/> <p> Note A No ISDN Channel message may indicate a problem with the ISDN lines between your system and the network.</p> <hr/> <ul style="list-style-type: none"> • Verify that the ISDN lines are connected and active. Perform the following steps: <ol style="list-style-type: none"> 1. From the Hardware Diagnostics application, click Test ISDN Lines. If a line does not reach the active state, make sure that it is connected properly. See the iPower installation documentation for information about how to connect ISDN lines. 2. If the ISDN lines activate, close the Hardware Diagnostics application and start the Collaboration application. 3. If you still have call problems and your switch type is DMS100, NI1, 5ESS G3, or 5ESS Multipoint, you may have a problem registering your SPIDs with the network. From the Operating Statistics application, check your ISDN configuration or contact your network provider. • Make sure that the number being dialed is correct and properly formatted and try the call again. Callers may need to dial 9 or include a long distance access code or country code. • Verify that the far-end system is in working order. Telephone the far-end site and find out if the system is turned on and is functioning properly.

Problem	Corrective Action
<p>ISDN call attempt has failed; the user has received an error message</p>	<ul style="list-style-type: none"> • Have the far-end system call your system. To find out if the problem exists in one direction only, ask the person at the far-end site to call your system. • Check the ISDN configuration. <ul style="list-style-type: none"> - Contact your ISDN service provider and verify that the ISDN lines are provisioned according to the <i>Preparing Your Network for Collaboration</i> document, which is available at www.polycom.com. - Check the configuration in the ISDN Setup page in AdminTools. (Obtain the correct numbers from your ISDN service provider.) • Call a known good ISDN number. • Run the ISDN Bit Error Rate Test. This test allows you to place a call from one line to another in order to verify line integrity. Select Start>Programs>Polycom iPower>Administrator>Network Test. If a line connects, then the line is good.
<p>Difficulty making LAN calls <i>(continued on next page)</i></p>	<ul style="list-style-type: none"> • Check the number, system name, or LAN address of the far-end system. Make sure that the number being dialed is correct and properly formatted and try the call again. • Make sure that the network cable is connected and secure. The LAN cable must be connected properly, as shown in the iPower installation documentation. • Verify that the far-end system is working. <ul style="list-style-type: none"> - To find out if the problem exists in one direction only, ask the person at the far-end site to call your system. - Telephone the far end and find out if the system is turned on and is functioning properly. Ask whether the far-end system is behind an IP network firewall. If it is, the far end must provide a way for LAN traffic to go through, which will allow a successful connection.

Problem	Corrective Action
Difficulty making LAN calls	<ul style="list-style-type: none"> - If you are using an extension or an alias to place the call to the far-end site, use the IP address instead. If you can place the call using the IP address, your H.323 gatekeeper or your access to the gatekeeper is faulty. Notify your network administrator. • Check the LAN configuration in the LAN Setup page in AdminTools. (Obtain correct numbers from your network provider.) • Call a known good LAN number.
The call briefly enters the "Connecting" state and then disconnects <i>(continued on next page)</i>	<ul style="list-style-type: none"> • Check the phone number, system name, or TCP/IP address to make sure that you are dialing a videoconferencing system. • Redial the call using a lower rate (1x512 to 1x384, 1x384 to 2x64, 2x64 to 2x56) because the far end or network may not support the call rate you requested. • Operationally test the lines for making outgoing calls. Perform the following steps: <ol style="list-style-type: none"> 1. Make a 1x512 call to another iPower system using a number that is known to be correct. 2. After the call connects, check the call rate from the Conference Statistics screen. <ul style="list-style-type: none"> - If the call connected at 1x512, all lines work. - If some lines do not come up, the lines may not be connected to the network properly. • Verify that the ISDN lines are connected and active. Perform the following steps: <ol style="list-style-type: none"> 1. From the Hardware Diagnostics application, click Test ISDN Lines. If a line does not reach the active state, make sure that it is connected properly. See the iPower installation documentation for information about how to connect ISDN lines.

Problem	Corrective Action
The call briefly enters the "Connecting" state and then disconnects	<ol style="list-style-type: none"> 2. If all ISDN lines activate, close the Hardware Diagnostics application and start the Collaboration application. 3. If you still have call problems and your switch type is DMS100, NI1, 5ESS G3, or 5ESS Multipoint, you may have a problem registering your SPIDs with the network. From the Operating Statistics application, check your ISDN configuration or contact your network provider.
Readiness message: Gatekeeper registration failed	<ul style="list-style-type: none"> • From the Operating Statistics application, check the gatekeeper configuration. • Notify the network administrator. • Place LAN calls using IP addresses that do not require a gatekeeper.
The system can make calls but cannot receive them	<ul style="list-style-type: none"> • From the Configuration Summary category of the Operating Statistics application, check the local phone numbers. • Run the ISDN Bit Error Rate Test. This test allows you to place a call from one line to another in order to verify line integrity. Select Start>Programs>Polycom iPower>Administrator>Network Test. If a line connects, then the line is good.
A call stays in the "Connecting" state	<ul style="list-style-type: none"> • Check the phone number, system name, or TCP/IP address to make sure that you are dialing a videoconferencing system. • Redial the call as "restricted".
The call connects at less than the requested rate; the system displays "Call connected at maximum available rate"	<ul style="list-style-type: none"> • Double-click the  Conference Statistics icon on the taskbar in the lower right-hand corner of the screen. Check the report and the far-end data. • Remain in the call at the reduced rate. The call is operating at the maximum rate supported by the far end. <hr/> <div style="display: flex; align-items: center;">  <p>A single-BRI system provides 1x128 maximum and a Quad-BRI system provides 1x512 maximum.</p> </div> <hr/>



Problem	Corrective Action
<p>The call connects at less than the requested rate; the system displays "Call connected at <rate>"</p>	<ul style="list-style-type: none"> • Operationally test the lines for making outgoing calls. Perform the following steps: <ol style="list-style-type: none"> 1. Call a known good number. If the call connects at the requested rate, all lines work. 2. After the call connects, check the call rate from the Conference Statistics screen. <ul style="list-style-type: none"> - If the call connected at 512, all lines work. - If some lines do not come up, the lines may not be connected to the network properly. • Verify that the ISDN lines are connected and active. Perform the following steps: <ol style="list-style-type: none"> 1. From the Hardware Diagnostics application, click Test ISDN Lines. If a line does not reach the active state, make sure that it is connected properly. See the iPower installation documentation for information about how to connect ISDN lines. 2. If all ISDN lines activate, close the Hardware Diagnostics application and start the Collaboration application. 3. If you still have call problems and your switch type is DMS100, NI1, 5ESS G3, or 5ESS Multipoint, you may have a problem registering your SPIDs with the network. From the Operating Statistics application, check your ISDN configuration or contact your network provider.

Solving Video Problems





Problem	Corrective Action
Far-end receives or transmits poor video	<ul style="list-style-type: none"> • Double-click the  Conference Statistics icon on the taskbar in the lower right-hand corner of the screen. Check the video statistics. <ul style="list-style-type: none"> - Check the Key frames. A large number or a steadily increasing number in this field indicates a network quality problem. - Redial the call or try connecting at a lower rate. • If the problem persists, call for service.
Poor local (near-end) video	<ul style="list-style-type: none"> • Make sure that all video, camera, and monitor cables are correctly installed and secure. (If necessary, consult the manual that came with your monitor.) • From the Hardware Diagnostics application, start Automated Testing. If the test passes, the video board is good. • From the Hardware Diagnostics application, click Test Video and select the appropriate video source. If no source is detected, perform the following steps: <ol style="list-style-type: none"> 1. Unplug the camera video cable and then plug it in again, or turn off the Camera and Microphone module, unplug the video cable, and then plug it in again. 2. Replace the video cable. 3. Change the cable connections. 4. If the test fails, the video board is faulty. Call for service. • If the problem persists, call for service.

Problem	Corrective Action
<p>No thumbnail or blank thumbnail or Video Readiness indication</p>	<ul style="list-style-type: none"> • Make sure that the video source is turned on. If you are using a laptop with or without an ImageShare or ImageShare II: <ul style="list-style-type: none"> - Make sure that the laptop is selected as the source of input in the Collaboration application. - Make sure that your laptop is enabled to send to an external screen (as you would do if you connected a projector to your laptop). Note that the laptop is added to the People and Content list. - Make sure that the laptop screen resolution is set to 480x640, 600x800, or 1024x768. <hr/> <p> Note If you use a screen resolution of 1024x768, make sure the refresh frequency is set to 75 Hz or lower.</p> <hr/> <ul style="list-style-type: none"> • From the Hardware Diagnostics application, start Automated Testing. If the test passes, the video board is good. • From the Hardware Diagnostics application, click Test Video and select the appropriate video source. If no source is detected, do the following: <ol style="list-style-type: none"> 1. Unplug the camera video cable and then plug it in again, or turn off the Camera and Microphone module, unplug the video cable, and then plug it in again. 2. Replace the video cable. 3. Change the cable connections. 4. If the test fails, the video board is faulty. Call for service. • If the problem persists, call for service.
<p>No video (VGA) output (blank VGA monitor)</p>	<ul style="list-style-type: none"> • Check all video and power cable connections to and from the VGA monitor. • Check the brightness setting on the monitor to be sure that it is not set to one extreme or the other.

Problem	Corrective Action
<p>Cannot control the camera using the remote or keyboard</p>	<ul style="list-style-type: none"> • From the Hardware Diagnostics application, start Automated Testing. <ul style="list-style-type: none"> - If the test passes, from the Hardware Diagnostics application, click Test Video and select the video source. If the source is detected, attempt to control the camera. - If the test fails, call for service. • If you still cannot control the camera, turn off the camera and do the following: <ul style="list-style-type: none"> - Unplug the camera cable(s) and plug them in again - Replace the video cable - Change the cable connections • Make sure that other commands from the remote control and keyboard work. • If the problem persists, call for service.
<p>No video (NTSC or PAL) output</p>	<hr/> <div style="display: flex; align-items: flex-start;"> <div style="margin-right: 10px;">  <p>Note</p> </div> <div> <p>The NTSC/PAL monitor is used only if in a call. If the system is not in a call, this monitor will not display video.</p> </div> </div> <hr/> <ul style="list-style-type: none"> • Make sure that all cables to and from the NTSC or PAL monitor are correctly installed and secure, and that the monitor power is on. • From the Operating Statistics or AdminTools application, check the system configuration for the NTSC or PAL settings. If appropriate, enable dual-monitor use and restart the collaboration system. • Make sure the far-end is sending video by checking the Receive field in Conference Statistics. (Conference Statistics verifies that you are receiving video from the far-end.) • From the Hardware Diagnostics application, start Automated Testing. <ul style="list-style-type: none"> - If the test passes, click Test Video and select the NTSC Color Bar video source. If the color bar does not appear on the NTSC/PAL monitor, call for service. - If the test fails, call for service.

Problem	Corrective Action
Slow video image in an ISDN call	<hr/> <div style="display: flex; align-items: flex-start;">  <p data-bbox="911 449 964 476">Note</p> </div> <p data-bbox="1015 394 1409 506">An ISDN line sends signals on one or more B channels. If the call is using only one channel, the video image becomes slow.</p> <hr/> <ul style="list-style-type: none"> <li data-bbox="898 573 1409 630">• Check to be sure that the call connected at the rate you requested. <ul style="list-style-type: none"> <li data-bbox="935 638 1409 749">- With the call still connected, double-click the  Conference Statistics icon on the taskbar in the lower right-hand corner of the screen. <li data-bbox="935 762 1409 873">- Check the Key frames. A large number or a steadily increasing number in this field indicates a network quality problem. Redial the call or try connecting at a lower rate.
Camera is in Standby mode (powered down)	<ul style="list-style-type: none"> <li data-bbox="898 898 1409 1010">• Minimize and then maximize the Collaboration application, click a mouse button, press a remote control button, or clear the screen saver. <li data-bbox="898 1022 1409 1079">• Turn off the camera (if necessary), unplug the video cable, and then plug it in again. <li data-bbox="898 1092 1409 1171">• From the Hardware Diagnostics application, click Test Video and attempt to control the camera. <li data-bbox="898 1184 1284 1211">• Restart the collaboration system. <li data-bbox="898 1224 1341 1251">• If the problem persists, call for service.
No output from VCR	<ul style="list-style-type: none"> <li data-bbox="898 1268 1409 1348">• Make sure that all power, audio, and video cables to and from the system, display, and VCR are correctly installed and secure. <li data-bbox="898 1360 1409 1417">• If your VCR requires that you select an output, choose the RCA or Composite output. <li data-bbox="898 1430 1409 1680">• Play a known good VCR tape. If the tape will not play, perform the following steps: <ol style="list-style-type: none"> <li data-bbox="935 1497 1312 1524">1. Restart the collaboration system. <li data-bbox="935 1537 1409 1617">2. From the Hardware Diagnostics application, click Test Video and select the VCR Video Source option. <li data-bbox="935 1629 1409 1680">3. Play a known good VCR tape again. If the tape still will not play, call for service.

Solving Audio Problems

Problem	Corrective Action
Far-end participants cannot hear you	<ul style="list-style-type: none"> • Make sure that the near end has not muted the call. A mute icon  appears in the status bar when the call is muted. • Make sure that all power and audio cables to and from the system, display, and peripherals are correctly installed and secure. • Ask the far-end participants to check their speakers.
Cannot hear the far-end participants	<ul style="list-style-type: none"> • Make sure that the far-end site has not muted the call. A mute icon  appears in the status bar when the call is muted. <hr/> <p> Note If you are in a call and in Full-Screen mode, enable the status bar in order to see the icon.</p> <hr/> <ul style="list-style-type: none"> • Check all volume controls (collaboration application, speakers, etc.) • Make sure that all speaker cables to the system are correctly installed and secure. • From the Operating Statistics application, start the Local Channel loopback test (ISDN systems). • From the Hardware Diagnostics application, start Automated Testing. <ul style="list-style-type: none"> - If the test passes, click Test Audio and select one of the A/V Board-Generated or Motherboard-Generated options as the Audio Source. If you do not hear the audio tones or noise, call for service. - If the test fails, call for service.
Poor audio from the far-end system <i>(continued on next page)</i>	<ul style="list-style-type: none"> • Double-click the  Conference Statistics icon on the taskbar in the lower right-hand corner of the screen. Check the audio statistics. • Check for network errors. • From the Hardware Diagnostics application, start Automated Testing.

Problem	Corrective Action
<p>Poor audio from the far-end system</p>	<ul style="list-style-type: none"> From the Hardware Diagnostics application, click Test Audio. Select one of the A/V Board-Generated or Motherboard-Generated options as the Audio Source. If the audio tones or noise have poor quality, call for service.
<p>Cannot hear any audio or the volume is too low or too high</p>	<ul style="list-style-type: none"> If you are in a call, adjust the volume by using the control buttons on the remote or by manipulating on-screen controls with the keyboard. If your audio speakers have their own volume control, check that the control is set appropriately. Listen for the dial-up tones during the dial-up process. From the Hardware Diagnostics application, start Automated Testing. If the test fails, call for service. From the Hardware Diagnostics application, click Test Audio. Select one of the A/V Board-Generated or Motherboard-Generated options as the Audio Source. If the audio tones or noise have poor quality, call for service.
<p>Poor Automatic Gain Control (AGC). Far end detects variations in audio from near-end sources that are different distances from the microphone</p>	<ul style="list-style-type: none"> From the Operating Statistics application, check the audio settings. If this is a custom audio system, try to bypass AGC and Echo Cancellation and revert back to the PowerMic to see if the symptoms persist.
<p>Poor Automatic Noise Suppression (ANS). Far end hears near-end background noise</p>	<ul style="list-style-type: none"> From the Operating Statistics application, check the audio settings.
<p>Poor Integrated Dynamic Echo Cancellation (IDEC™). Far-end participants hear echoes of themselves</p>	<ul style="list-style-type: none"> From the Operating Statistics application, check the audio settings.

Solving ImageShare and ImageShare II Problems

Problem	Corrective Action
<p>Data or images will not pass through the Monitor or VGA In connector of the ImageShare device</p>	<ul style="list-style-type: none"> • Make sure that all cables to and from the ImageShare device are correctly installed and secure. • If you are using a laptop with the ImageShare, perform the following steps: <ol style="list-style-type: none"> 1. Make sure that the laptop screen has been sent to the ImageShare device by enabling your laptop to send to an external screen (as you would do if you connected a projector to your laptop). Make sure that the laptop is added to the People and Content list. 2. Make sure that the laptop screen resolution, capture resolution, and frequency settings are correct (1024x768 @ 75 hz). See the laptop documentation if you need information on setting up the laptop to send video from its VGA port. 3. From the Hardware Diagnostics application, start Automated Testing. <ul style="list-style-type: none"> - If the test passes, from the Hardware Diagnostics application, start Test Video and select the ImageShare Video Source option. If the PC or laptop video image does not appear, call for service. - If the test fails, call for service.
<p>Projector connected to the ImageShare is not displaying output</p>	<ul style="list-style-type: none"> • Make sure that all cables to and from the ImageShare device are correctly installed and secure. • Consult the documentation that came with the projector.

Problem	Corrective Action
<p>ImageShare capture feature is not working (no thumbnail)</p>	<ul style="list-style-type: none"> • Make sure that all cables to and from the ImageShare device are correctly installed and secure. • Make sure that the laptop screen has been sent to the ImageShare device by enabling your laptop to send to an external screen (as you would do if you connected a projector to your laptop). Note that an icon for the laptop is added to the People and Content list. • Restart the collaboration system. • From the Hardware Diagnostics application, start Automated Testing. <ul style="list-style-type: none"> - If the test passes, from the Hardware Diagnostics application, start Test Video; select the appropriate Video Source option; if the video image does not appear, call for service. - If the test fails, call for service.
<p>Pushing the blue Selection button does not display the laptop content</p>	<ul style="list-style-type: none"> • Choose the ImageShare device on the People and Content list. • If the ImageShare device becomes the Content source: <ul style="list-style-type: none"> - Make sure that all cables to and from the ImageShare device are correctly installed and secure. - Make sure that the laptop settings are correct. - Make sure that the laptop is recognized as the source of input. • If the ImageShare device does not become the Content source, restart the collaboration system.



System Default Settings

The following table lists the system default settings. Options not listed do not have default settings.

Option	Default Setting
Allow far-end sites to control the camera on this system	Enabled
Allow ISDN calls on this system	Enabled
Allow near-end Automatic Camera Pointing	Enabled
Allow rate adaptation to 56 kbps if 64 kbps fails	Disabled in Italy Enabled in all other countries
Answer incoming video calls automatically	Disabled
Audio algorithm for ISDN (H.320) calls	Automatic
Audio algorithm for LAN (H.323) calls	Automatic
Components to monitor	Remote devices (remote control and LAMB) Color depth and resolution Camera(s) Microphone(s)
Countdown for	30 seconds
Display number last dialed	Always
Dual Images	Enabled
Encoding law for G.711	μ -law (in North America, Japan, and Korea) a-law (in most other parts of the world)
ISDN bandwidth: Default	Standard
ISDN bandwidth: Premium	1x512 kbps (normal configurations)
ISDN bandwidth: Standard	1x384 kbps (normal configurations)

Option	Default Setting
[LAN] Incoming call transmission bandwidth	4 Mbps
[LAN] Outgoing call bandwidth: Default	Standard
[LAN] Outgoing call bandwidth: Premium	1x768 kbps
[LAN] Outgoing call bandwidth: Standard	1x384 kbps
Local Directory (stored on system)	Enabled
Log file security	Disabled
Log off automatically after	30 minutes
Logon	Auto Logon
Mute audio for automatically answered calls	Enabled
Number type	Unknown
Numbering plan	Unknown
Pan direction of near-end camera	Normal
Picture-in-Picture (PIP) position on second monitor	Bottom right
Put the system in Standby mode after	Disabled
Transmit a Sending Complete information element	Enabled for Euro ISDN, NET3 (Taiwan), and VN3 Disabled for all other dialects
Use a second monitor	Disabled
Use Automatic Gain Control (AGC)	Enabled
Use Automatic Gain Control (AGC) for auxiliary audio source	Enabled
Use echo cancellation (IDEC)	Enabled
Use noise suppression	Enabled
Use this line for network management via RAS	None
Use this line for voice-add and voice-only calls	Line 4
VCR setup	One VCR (for both recording and playback)
Video algorithm for ISDN (H.320) calls	Automatic
Video algorithm for LAN (H.323) calls	Automatic

A

ACP. *See* Automatic Camera Pointing

adapter, configuring 14

administrator, contacting 41

AdminTools

- accessing 13
- accessing help for 13
- allowing data sharing using 17
- configuring audio using 15
- configuring multipoint using 18
- configuring network use using 15
- configuring remote management tools using 17
- configuring streaming using 16
- configuring video using 16
- customizing the system using 14
- description of 11
- documentation about 43
- maintaining the system using 17
- roadmap of 13
- setting up directories using 16
- setting up system security using 14

ANS (Automatic Noise Suppression), solving problems with 60

Application Log 36

applications

- adding to iPower system 32
- optional on iPower system 12
- standard on iPower system 11

audio

- adding to iPower system 11
- configuring 15
- setting for internal multipoint 18
- solving problems with 59

Auto Logon

- description of 19
- disabling 14

Automatic Camera Pointing (ACP) 4

Automatic Gain Control (AGC), solving problems with 60

Automatic Noise Suppression (ANS), solving problems with 60

auxiliary camera, description of 9

C

call

- setting preferences for 14
- viewing statistics for 35

Call Log, description of 36

camera

- adding additional 9
- configuring behavior of 16
- description of 4
- documentation about 43
- iPower 600 5
- iPower 900 5
- iPower 9000 4
- setting up sources of 16
- solving problems with 57

Camera and Microphone module 5

cart, description of 9

Central Directory. *See* directory

Collaboration application

- description of 11
- documentation about 43

components, optional for iPower system

- additional cameras 9
- cart 9
- display 8
- other hardware components 10
- VCR 10

components, standard for iPower system

- computer box 3
- ImageShare or ImageShare II 7
- main camera 4
- PowerMic 7
- remote control devices 5

computer box

- iPower 600 3
- iPower 900 4
- iPower 9000 3

computer unit 3

Conference Statistics

- Conference Statistics page 35
- viewing 35

Conference-on-Demand. *See* PathNavigator Conference-on-Demand

- configuration
 - of audio 15
 - of data sharing 17
 - of directories 16
 - of multipoint 18
 - of network use 15
 - of remote management tools 17
 - of streaming 16
 - of system 14
 - of video 16
- Configuration Summary
 - Configuration Summary page 34
 - listing settings 36
 - viewing 34
- control panel, allowing use of 14
- custom control panel, allowing use of 14
- customizing the system 14

D

- data sharing, allowing 17
- default settings, for iPower system 63
- default user account 20
- directory
 - backing up Local before reinstalling 28
 - Directory Services Setup 12
 - setting up Central 16
 - setting up Local 16
- Directory Services. *See* directory
- disk space, conserving 37
- display
 - adding second monitor 16
 - description of 8
 - solving problems with 56
 - using two displays 9
- document camera, description of 9
- Document Server
 - advantages of 24
 - configuring 17
 - description of 12
 - installing software for 24
 - setting up 24
 - system requirements of 24
 - tips and guidelines for 25
- documentation
 - finding information in 42
 - list of documents 42
- domain account 20
- dual images, enabling or disabling 16

dual monitor 9

F

- File Transfer
 - configuring 17
 - description of 11
- flicker reduction, enabling 16

G

- gatekeeper, setting up 15
- gateway, setting up 15
- Getting Started Guide*
 - customizing 40
 - location of 40
- Global Management System
 - description of 22
 - disabling 23
 - removing an IP address 23
 - setting up user account for 23

H

- hardware
 - components, optional 8
 - components, standard 3
 - documentation about installing iPower system 42
 - documentation about testing 44
- Hardware Diagnostics
 - description of 11
 - description of Error Log 36
 - documentation about 44
- headset, adding to iPower system 11
- help, list of online help systems 42

I

- ImageShare
 - documentation about 43
 - iPower 600 7
 - iPower 900 7
 - iPower 9000 7
 - solving problems with 61

ImageShare II
 documentation about 43
 iPower 600 7
 iPower 9000 7
 solving problems with 61

IMUX, setting up 15

information, providing to users 39

installation
 documentation about 42
 reinstalling the iPower system 28
 solving problems during 46

Integrated Dynamic Echo Cancellation (IDEC),
 solving problems with 60

iPower 70 Room Camera
 description of 5
 documentation about 43

iPower 80 Dynamic Locating Camera
 description of 5
 documentation about 43

iPower Documentation CD, list of documents on 42

iPower Executive, documentation about 43

iPower system
 accessing and viewing logs for 36
 adding applications to 32
 AdminTools Roadmap 13
 conserving disk space for 37
 customizing the system 14
 default settings for 63
 description of 1
 finding information in documentation 42
 hardware components, optional 8
 hardware components, standard 3
 ImageShare or ImageShare II 7
 installation documentation about 42
 iPower 600 description 2
 iPower 900 description 2
 iPower 9000 description 2
 monitoring system statistics 32
 providing users with information 39
 restoring the system 28
 setting up additional software on 20
 setting up system security 14
 setting up the log on process on 19
 setting up virus protection for 37
 software applications, optional 12
 software applications, standard 11
 tasks you do rarely 19
 tasks you do regularly 31
 telling users how to contact system administrator 41

tips for helping users 39
 troubleshooting 45
 updating information for 17

ISDN, setting up 15

K

keyboard
 description of 5
 iPower 600 6
 iPower 900 6
 iPower 9000 6
 solving problems with 47

L

LAMB. *See* Look-At-Me-Button

LAN, setting up 15

laptop, adding to iPower system 11

Local Directory. *See* directory

local user account 20

Locked Settings 14

logging in. *See* logon

logoff, setting options 14

logon
 choosing logon options 19
 choosing method 14
 setting up 19

logs
 accessing and viewing 36
 Application Log 36
 Call Log 36
 Configuration Summary 36
 Hardware Diagnostics Error Log 36
 saving numbers in Call Log 14
 Security Log 36
 System Log 36

Look-At-Me-Button, adding to iPower system 11

M

maintenance
 of system using AdminTools 17
 restoring the system 28

Management Information Bases. *See* MIBs

MIBs, installing 22

- microphone
 - configuring 15
 - documentation about 43
 - PowerMic 7
 - Zoom Mic 5
- monitor
 - solving problems with 57
- monitor. *See* display
- multipoint, configuring 18
- muting, solving problems with 59

N

- NAT, configuring 14
- NetMeeting Chat, description of 11
- network
 - configuring use of 15
 - installing network management software 22
 - network management station (NMS) 22
 - solving problems with 49
- network management station (NMS) 22
- Network Manager
 - adding to SNMP management 22
 - description of 12
- NTSC/PAL display 9

O

- online help
 - accessing 42
 - list of 42
- Operating Statistics
 - description of 11
 - Operating Statistics page 33
 - starting 32

P

- PathNavigator Conference-on-Demand
 - configuring 25
 - description of 25
 - placing a call using 26
 - uses of 25
- People and Content list, adding applications to 14
- picture-in-picture (PIP). *See* PIP
- PIP
 - changing position of 14
 - description of 8

- Polycom iPower system. *See* iPower system
- Polycom Technical Support v
- port range, configuring 14
- PowerCam Plus
 - description of 4
 - documentation about 43
- PowerCam, description of 4
- PowerMic
 - description of 7
 - documentation about 43
- Premier Cart
 - description of 9
 - documentation about 43
- printer, adding to iPower system 10
- problems, solving. *See* troubleshooting
- projector, adding to iPower system 11

Q

- QoS, configuring 14
- Quality of Service, configuring 14
- Quick Tips Sheet*, sending to users 39

R

- RAS, setting up 17
- Readiness Monitoring, setting up 17
- regulatory, documentation about 42
- reinstalling, system 28
- Release Bulletin, location of 44
- remote control devices
 - iPower 600 6
 - iPower 900 6
 - iPower 9000 5
 - solving problems with 47
- remote management
 - description of software for 20
 - SNMP management 22
 - using tools for 17
 - WebRemote 20
- restoring, system 28
- room audio input devices, adding to iPower system 11

S

- scanner, adding to iPower system 10

- security
 - setting up for system 14
 - setting up virus protection 37
- Security Log 36
- serial devices, adding to iPower system 10
- server. *See* Document Server
- service, contacting Polycom v
- settings, locking 14
- Setup Wizard, description of 11
- SNMP management
 - adding iPower Network Manager 22
 - configuring system for 17
 - documentation about 44
 - enabling 22
 - installing iPower MIBs 22
 - setting up network management station (NMS) 22
- software
 - adding applications 32
 - applications, optional 12
 - applications, standard 11
 - Document Server 24
 - for remote management 20
 - Global Management System 22
 - PathNavigator Conference-on-Demand 25
 - reinstalling the system software 28
 - setting up additional 20
 - WebOffice 26
- solving problems. *See* troubleshooting
- space, conserving on disk 37
- speakers, defining number of 15
- Standard Windows logon
 - description of 19
 - setting up user accounts for 20
- Standby Mode, configuring 14
- startup, solving problems during 46
- statistics. *See* system statistics
- streaming, configuring 16
- support, contacting Polycom v
- SVGA/XGA display 9
- system administrator, contacting 41
- System Logs, description of 36
- system management. *See* AdminTools
- System Software* CD, applications on 11

- system statistics
 - monitoring 32
 - starting Operating Statistics 32
 - viewing detailed 32
 - viewing statistics for current call 35
 - viewing the Configuration Summary 34
- system. *See* iPower system

T

- tasks
 - accessing and viewing logs 36
 - adding applications 32
 - conserving disk space 37
 - in *Getting Started Guide* 42
 - in *Quick Tips Sheet* 42
 - monitoring system statistics 32
 - restoring the system 28
 - setting up additional software 20
 - setting up the log on process 19
 - setting up virus protection 37
- technical support, Polycom v
- Thin Display Adaptor, documentation about 43
- troubleshooting 45
 - audio problems 59
 - general system problems 47
 - ImageShare problems 61
 - installation problems 46
 - network problems 49
 - startup problems 46
 - video problems 55

U

- USB devices, adding to iPower system 10
- user access, managing 19
- user account
 - domain account 20
 - iPower system default user account 20
 - local user account 20
 - setting up 20
- User Guide. *See* *Getting Started Guide*
- users
 - finding information in documentation 42
 - providing with information they need 39
 - telling how to contact system administrator 41
 - tips for helping 39

Utility Cart

- description of 9
- documentation about 43

V

VCR

- adding 16
- solving problems with 58
- using with iPower system 10

video

- configuring 16
- setting for internal multipoint 18
- setting up video sources 16
- solving problems with 55

virus, setting up protection against 37

Vortex, adding to iPower system 11

W

Web site, Polycom v

WebOffice

- accessing 27
- description of 26

WebRemote

- configuring system for 17
- documentation about 44
- enabling 20
- requirements for 20
- using 21

whiteboard, adding to iPower system 10

Windows logon

- description of 19
- setting up user accounts for 20

Z

Zoom Mic 5